

KINGPINLESS STYLE 112 SWIVEL ON SWIVEL (SoS)



FEATURES

- Swivel Section:** Sealed precision ball bearing with hardened raceways and neoprene seals.
- Legs:** 1/4" x 2" steel, formed and continuously welded on the inside and outside of the yoke base.
- Kingpin:** Kingpinless style design.
- Axle:** 1/2" diameter.
- Lubrication:** Sealed ball bearing is lubricated and requires zero maintenance.
- Wheels:** 6" to 10" diameter wheels are available with sealed precision ball bearings.
- Finish:** Clear zinc plating.

APPLICATIONS

Excellent for production racks and fixtures, parts bins, conveyor systems, and other applications where maintenance-free casters and ergonomics are concerns. Also works well for carts and Automated Guided Vehicles that need to maneuver in tight spaces.

BENEFITS

The 112 series dual swivel section is maintenance free with its sealed precision ball bearing in the swivel section and in the wheels. The dual swivel action reduces castering effect, making it possible for a cart to go forwards and back in a straight line. This improves maneuverability in tight spaces and help reduce ergonomic push/pull forces.

OPTIONS

- BRAKES**
- Cam: C^
- Poly Lock: P*
- Face Contact: F
- TOE GUARD:** TG

* For wheels with a diameter > 6"
^ Not for use on TWERGO® Wheels.

MAXIMUM CAPACITY

1,500 lbs.

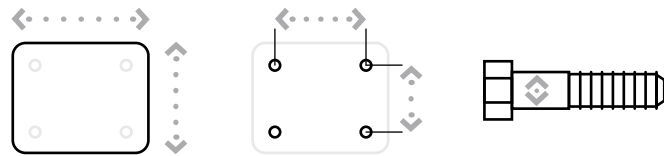

Top Plate Size	Bolt Hole Spacing	Bolt Diameter
Standard: 4.5" x 6.25"	2.438" x 4.938" Slotted to 3.375" x 5.25"	0.5"
Optional Top Plate 70: 5" x 7.25"	3.375" x 5.25" Slotted to 4.125" x 6.125"	0.5"

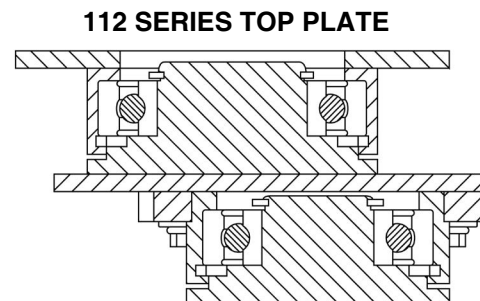

KINGPINLESS STYLE 112 SWIVEL ON SWIVEL (SoS)

PRECISION BALL BEARING

Diameter	Width	Material	Capacity	OAH	Swivel Radius	Swivel Lead	Part Number	Weight
6	2.00	ErgoTread	910	9.88	7.32	4.25	112-06202-40-1	22.30
6	2.00	T/R Polyurethane	960	9.88	7.32	4.25	112-06202-61-1	22.30
6	2.00	T/R-95 Polyurethane	1,400	9.88	7.32	4.25	112-06202-91-1	22.30
6	2.00	HPPT Polyurethane	1,500	9.88	7.32	4.25	112-06202-90-1	22.30
6	2.00	ErgoTread	910	9.88	7.32	4.25	112-06202-44-1	22.30
6	2.00	T/R Polyurethane	960	9.88	7.32	4.25	112-06202-93-1	22.30
6	2.00	T/R-95 Polyurethane	1,400	9.88	7.32	4.25	112-06202-94-1	22.30
8	2.00	ErgoTread	1,178	12.50	8.31	4.25	112-08202-40-1	26.30
8	2.00	T/R Polyurethane	1,240	12.50	8.31	4.25	112-08202-61-1	26.30
8	2.00	T/R-95 Polyurethane	1,500	12.50	8.31	4.25	112-08202-91-1	26.30
8	2.00	HPPT Polyurethane	1,500	12.50	8.31	4.25	112-08202-90-1	26.30
8	2.00	ErgoTread	1,180	12.50	8.31	4.25	112-08202-44-1	26.30
8	2.00	T/R Polyurethane	1,240	12.50	8.31	4.25	112-08202-93-1	26.30
8	2.00	T/R-95 Polyurethane	1,500	12.50	8.31	4.25	112-08202-94-1	26.30
10	2.00	T/R Polyurethane	1,500	13.88	9.30	4.25	112-10202-61-1	30.30
10	2.00	T/R-95 Polyurethane	1,500	13.88	9.30	4.25	112-10202-91-1	30.30
10	2.00	ErgoTread	1,500	13.88	9.30	4.25	112-10202-44-1	30.30
10	2.00	T/R Polyurethane	1,500	13.88	9.30	4.25	112-10202-93-1	30.30
10	2.00	T/R-95 Polyurethane	1,500	13.88	9.30	4.25	112-10202-94-1	30.30

Capacity listed is for manual operation. For powered operations, consult factory.
All dimensions are in inches. All weights are in pounds.