

EXTRA HEAVY DUTY 99 SERIES

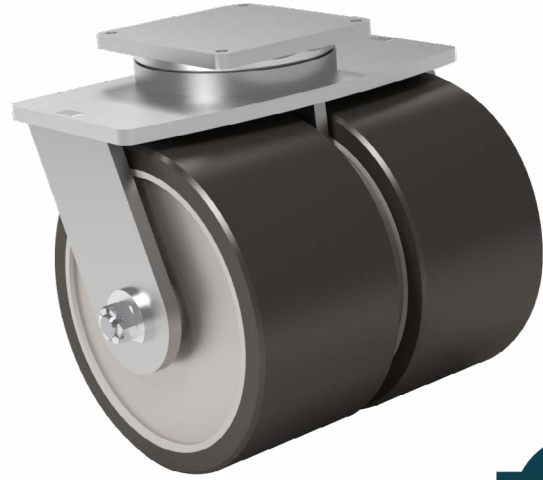

**FOR
SEVERE
DUTY**

MAXIMUM CAPACITY

35,000 lbs.

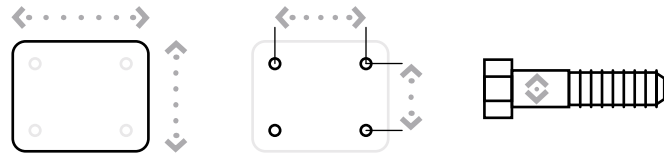

Top Plate Size	Bolt Hole Spacing	Bolt Diameter
Standard: 14" x 14"	12" x 12"	0.75"

99 SERIES TOP PLATE

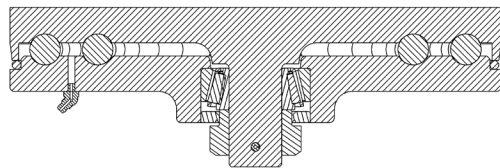

FEATURES

Swivel Section: Machined from C-1045 hot forged steel which has been precision machined for bearings. The swivel section features dual 9" and 12" diameter through hardened load races that use 7/8" diameter steel balls.

Legs: 3/4" legs are continuously welded both inside and outside for the greatest strength.

Kingpin: 1-1/2" diameter kingpin integrally forged into top plate features a slotted adjusting nut and heavy-duty 1-1/2" sealed tapered thrust bearing.

Axle: 2" alloy steel

Lubrication: Pre-lubricated before shipping.

Wheels: Available in single and dual-wheel configurations. Single wheel diameters range from 12" to 28". Dual wheel diameters range from 10" to 22" as standard.

Finish: Black Powder Coat.

APPLICATIONS

Optimal for die handling, marine and automotive applications, the 99 Series also meets the needs for aerospace and aircraft ground support equipment.

BENEFITS

The 99 Series platform with heavy-duty swivel casters is the ideal choice when payload protection far exceeds the capacity of the caster. The dual load race design assures smooth rotation of the caster and superior load capacity. Priced at production prices, the series offers flexibility and comfort in product design.

OPTIONS

BRAKES

Poly Lock: P
Face Contact: F

SWIVEL LOCKS

Vertical Mounted: V
Heavy Duty: HDL

SEALED WHEELS: SW

TOE GUARD: TG

** For wheels with a diameter > 6"
99 series swivel sections are used as a platform for many custom designed applications. Please consult the factory.*

EXTRA HEAVY DUTY 99 SERIES

STRAIGHT ROLLER NEEDLE BEARING (SINGLE WHEEL)

Diameter	Width	Material	Capacity	OAH	Swivel Radius	Swivel Lead	Part Number	Weight
12	5.00	Ductile Iron	18,000	16.50	9.34	3.00	99-12501-12-1	291.00
12	5.00	H.D. Hard Polyurethane (70D)	7,500	16.50	9.34	3.00	99-12501-67-1	196.00
15	9.00	H.D. Soft Polyurethane	8,700	19.50	11.88	3.50	99-15901-69-1	
18	9.00	H.D. Soft Polyurethane	10,900	22.00	14.23	4.50	99-18901-69-1	305.00
22	8.00	H.D. Soft Polyurethane	11,000	26.00	16.98	5.50	99-22801-69-1	
22	12.00	H.D. Soft Polyurethane	17,500	26.00	17.56	5.50	99-22121-69-1	
28	12.00	H.D. Soft Polyurethane	21,000	32.00	20.88	6.00	99-28121-69-1	
28	16.00	H.D. Soft Polyurethane	29,000	32.00	21.54	6.00	99-28161-69-1	

STRAIGHT ROLLER NEEDLE BEARING (DUAL WHEEL)

Diameter	Width	Material	Capacity	OAH	Swivel Radius	Swivel Lead	Part Number	Weight
10	4.00	H.D. Forged Steel	35,000	14.50		3.00	2-99-10401-21-1	255.00
12	5.00	Ductile Iron	35,000	16.50		3.00	2-99-12501-12-1	436.00
12	5.00	H.D. Hard Polyurethane (70D)	15,000	16.50		3.00	2-99-12501-67-1	244.46
18	9.00	H.D. Soft Polyurethane	21,800	22.00		4.50	2-99-18901-69-1	533.88
22	8.00	H.D. Soft Polyurethane	23,000	26.00		5.50	2-99-22801-69-1	
22	12.00	H.D. Soft Polyurethane	35,000	26.00		5.50	2-99-22121-69-1	1,048.00

PRECISION TAPERED BEARING (DUAL WHEEL)

Diameter	Width	Material	Capacity	OAH	Swivel Radius	Swivel Lead	Part Number	Weight
18	7.00	H.D. Forged Steel	50,000	24.00	16.56	5.50	2-99HD-18709-20-1	
22	12.00	H.D. Hard Polyurethane (70D)	35,000	28.00	21.02	5.50	2-99HD-22129-96-1	
28	16.00	H.D. Soft Polyurethane	50,000	34.00	25.56	5.50	2-99HD-28169-69-1	1,675.00

THE 99 SERIES PLATFORM CAN BE HIGHLY CUSTOMIZED FOR A BROAD RANGE OF APPLICATIONS.
All dimensions are in inches. All weights are in pounds.